

DLC Display Co., Limited

德爾西顯示器有限公司



MODEL No:DLC0350BMG-1

TEL: 86-755-86029824

FAX: 86-755-86029827

E-MAIL: sales@dlcdisplay.com

WEB: www.dlcdisplay.com



Record of Revision

Date	Revision No.	Summary
2010-07-30	1.0	Rev 1.0 was issued
2010-08-07	1.1	Modify Optical Specification
2011-03-30	1.2	Modify Optical Specification
2012-07-10	1.3	IC update
2013-06-18	1.4	SPECIFY THE CENTER OF THE DISPLAY

1. Scope

This data sheet is to introduce the specification of DLC0350BMG-1 active matrix 262k color TFT module. It is composed of a color TFT-LCD panel, driver ICs, FPC and a backlight unit. The 3.5" display area contains 240 (RGB) x 320 pixels.

2. Application

Digital equipments which need color display outdoor, mobile navigator/video systems.

3. General Information

Item	Contents	Unit
Size	3.5	inch
Resolution	240(RGB) X 320	/
Interface	RGB 18 bits	/
Color Depth	262K dithering	/
Technology type	a-si TFT	/
Pixel pitch	0.2235x0.2235	mm
Pixel Configuration	R.G.B. Vertical Stripe	
Outline Dimension (W x H x D)	64.0x85.0x2.93	mm
Active Area	53.64x71.52	mm
Display Mode	Transflective	/
Viewing Direction	6 o'clock	/
Backlight Type	LED	/
Driver IC	ILI9341	/

5. Interface signals

No	Symbol	Description	Remarks
1	VL1	Power for LED(High voltage)	
2	GND	Power Ground	
3	VL2	Power for LED(Low voltage)	
4	GND	Power Ground	
5	VSHD	Power supply for digital	
6	GND	Power Ground	
7	GND	Power Ground	
8	GND	Power Ground	
9	VSYNC	Vertical sync. in RGB mode	
10	GND	Power Ground	
11	RESET	Reset(Low active)	
12	GND	Power Ground	
13	GND	Power Ground	
14	GND	Power Ground	
15	CS	Chip select input(Low enable)	
16	GND	Power Ground	
17	SDO	Serial data output	
18	SDI	Serial data input	
19	GND	Power Ground	
20	SCL	Serial interface clock	
21	GND	Power Ground	
22	B5	Blue data	
23	B4	Blue data	
24	B3	Blue data	
25	B2	Blue data	
26	B1	Blue data	
27	B0	Blue data	
28	ENAB	Data enable in RGB mode	
29	GND	Power Ground	
30	HSYNC	Horizontal sync signal	
31	GND	Power Ground	
32	DCLK	Pixel clock signal in RGB mode	
33	GND	Power Ground	
34	G5	Green data	
35	G4	Green data	
36	G3	Green data	
37	G2	Green data	
38	G1	Green data	
39	G0	Green data	
40	GND	Power Ground	
41	R5	Red data	
42	R4	Red data	
43	R3	Red data	
44	R2	Red data	
45	R1	Red data	
46	R0	Red data	
47	GND	Power Ground	
48	GND	Power Ground	
49	GND	Power Ground	
50	GND	Power Ground	

Corresponded connector:FH12A-50S-0.5SH

6. Absolute maximum Ratings

6.1. Electrical Absolute max. ratings

Parameter	Symbol	MIN	MAX	Unit	Remark
Power Supply Voltage	VSHD	-0.3	4.6	V	
Driver supply voltage	VGH-VGL	-0.3	32.0	V	
Logic input voltage	VIN	-0.3	VSHD+0.3	V	

6.2. Environment Conditions

Item	Symbol	MIN	MAX	Unit	Remark
Operating Temperature	TOPR	-20	60	°C	
Storage Temperature	TSTG	-30	70	°C	

6.3. LED Backlight Absolute max. ratings

Item	Symbol	MIN	MAX	Unit	Remark
Back Light Forward Current	ILED	--	25	mA	For each LED

7. Electrical Specifications

7.1 Electrical characteristics

GND=0V, Ta=25°C

Item		Symbol	MIN	TYP	MAX	Unit	Remark
Power Supply Voltage		VDD	2.5	2.8	3.3	V	
Gate on voltage		VGH	13.5	15.0	16.5	V	
Gate off voltage		VGL	-11.0	-10.0	-9.0	V	
Input Signal Voltage	Low Level	VIL	0	--	0.3*VDD	V	
	High Level	VIH	0.7*VDD	--	VDD	V	
Output Signal Voltage	Low Level	VOL	-	--	0.3*VDD	V	
	High Level	VOH	0.7*VDD	--	-	V	
Current consumption		Icc		15		mA	

7.2 LED Backlight

Ta=25°C

Item	Symbol	MIN	TYP	MAX	Unit	Remark
Forward Current	IF	--	20	25	mA	6LEDs serial
Forward Voltage	VF	--	19.2	--	V	
Power Consumption	WBL	--	384	--	mW	

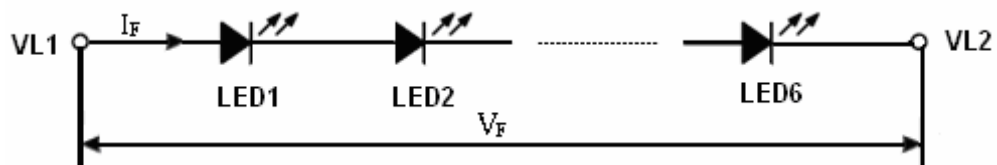

7.3 Schematic of LCD module system

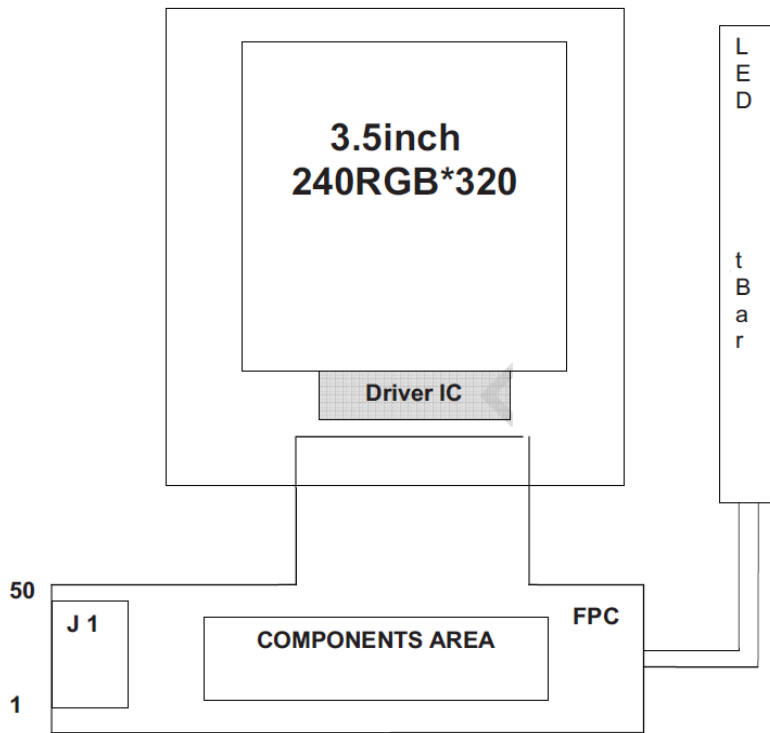

8. Command/AC Timing

8.1 Signal AC Timing

Parameter	Description	Rating			Unit
		MIN	TYP	MAX	
tSYNCS	VSYNC/HSYNC setup time	15			ns
tSYNCH	VSYNC/HSYNC hold time	15			ns
tENS	ENAB setup time	15			ns
tENH	ENAB hold time	15			ns
tPOS	Data setup time	15			ns
tPDH	Data hold time	15			ns
PWDH	DCLK high-level period	15			ns
PWDL	DCLK low-level period	15			ns
tCYCD	DCLK cycle time	15			ns
trgbr , trgbf	DCLK,HSYNC,VSYNC rise/fall			15	ns

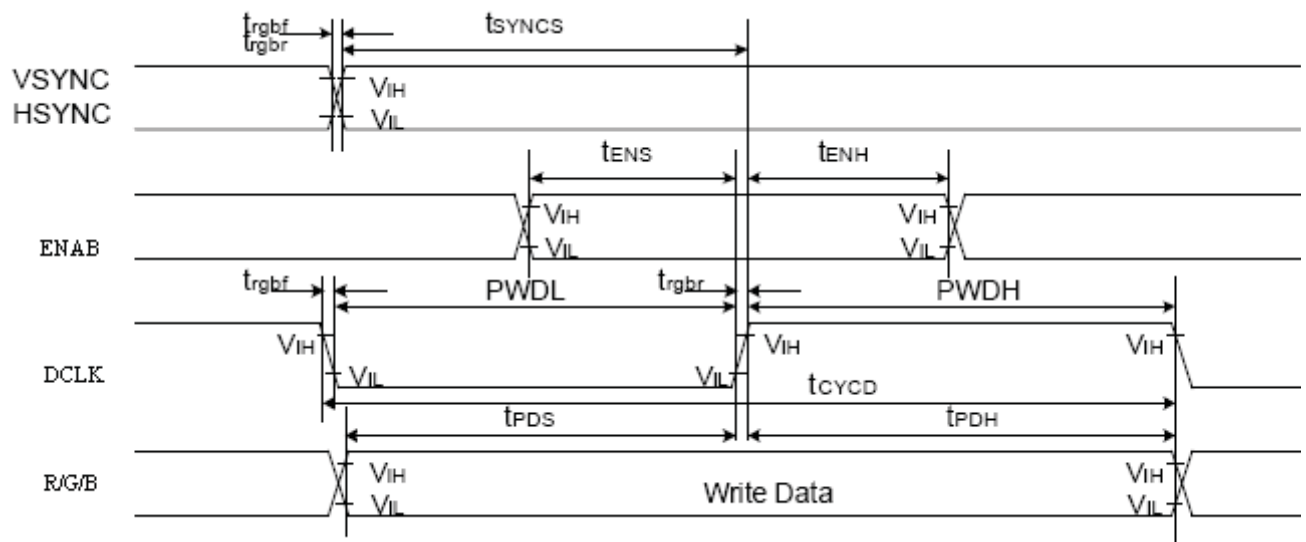

RGB Interface Timing

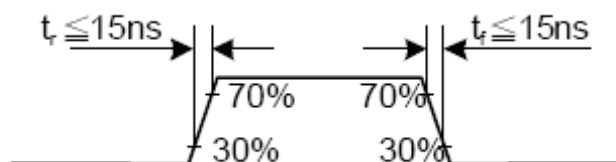

Input signal's rise and fall times

8.2 Recommend RGB Interface Timing

Parameter	Description	Rating			Unit
		MIN	TYP	MAX	
DCLK	DCLK frequency(fDCYC)		5.64	10	MHz
	DCLK period(tDCYC)	100	177.15		ns
HSYNC	Horizontal(Thd)	240			
	Horizontalline(Th)		310		DCLK
	Horizontal blank(Thb)	56	60		
	Horizontal front porch(Thfp)	2	10	16	
VSYNC	Vertical display area(Tvd)	320			
	Vsync period time(Tv)		328		
	Vsync blank(Tvb)	2	4		
	Vsync Front porch(Tvfp)	2	4		

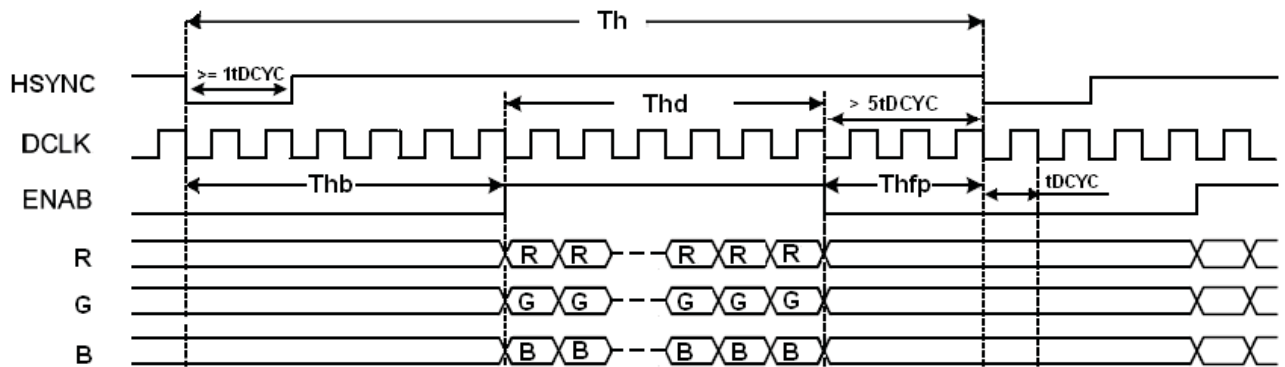
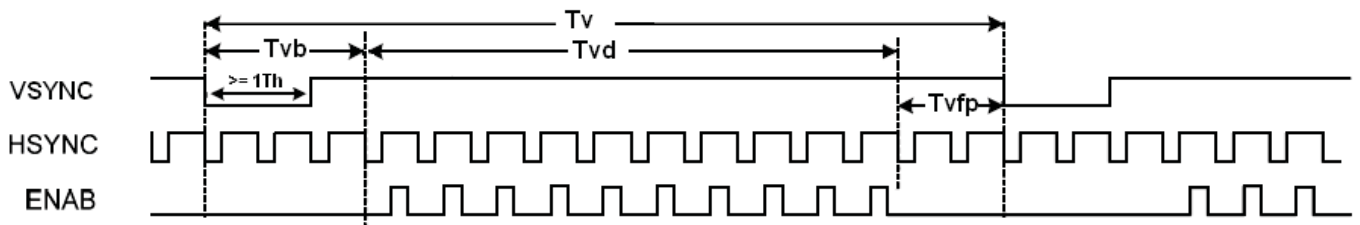

Recommend RGB Interface Timing

8.3.3-Wire 9-BIT Serial Interface

8.3.1 3-Wire 9-Bit data serial interface write mode

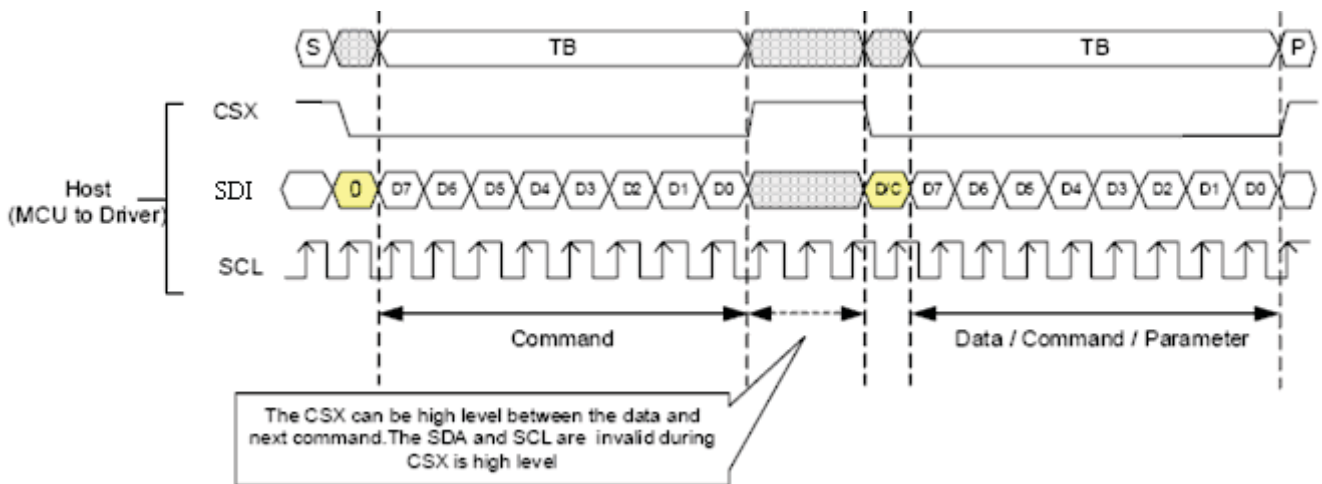

3-Wire 9-Bit Serial Interface I Bus Protocol, Write to Register or Display RAM

Note: D/C =0, Transfer Command; D/C =1, Transfer Data.

8.3.2 3-Wire 9-Bit data serial interface read 1-byte mode

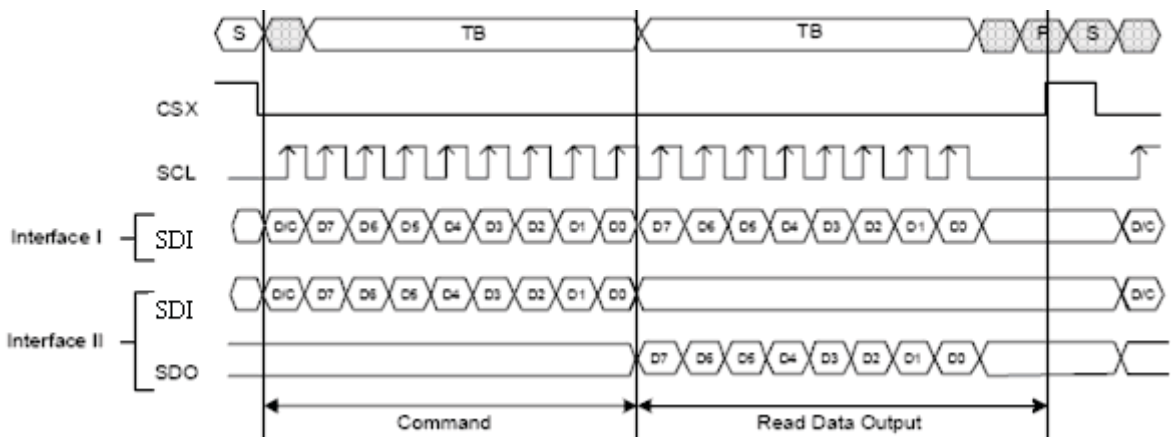

3-Wire 9-Bit Serial Interface I/II Bus Protocol, Read 1-Byte From Register

Note: D/C=0, Transfer Command; D/C=1, Transfer Data.

8.3.3 3-Wire 9-Bit data serial interface read 3-byte mode

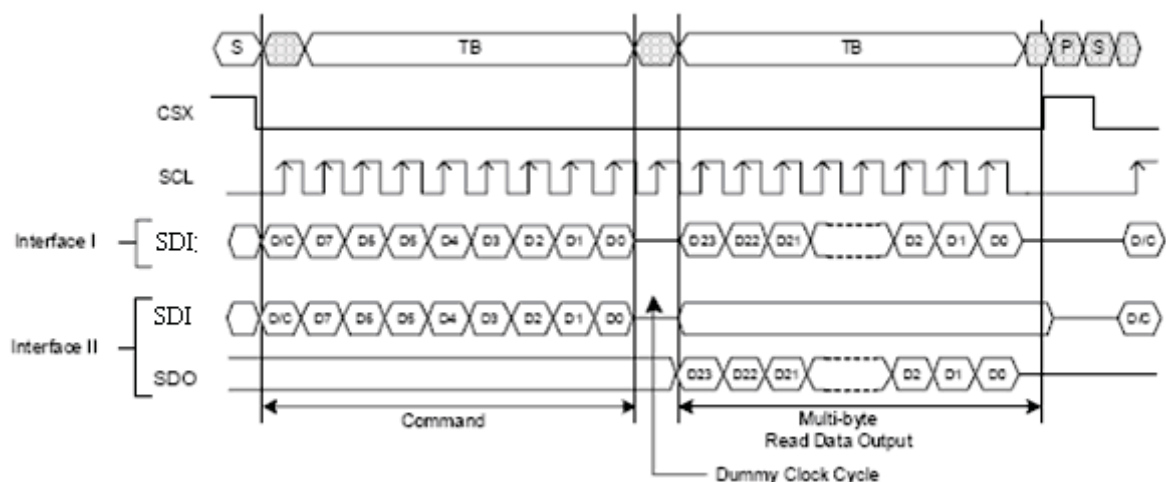

3-Wire 9-Bit Serial Interface I/II Bus Protocol, Read 3-Byte From Register

Note: D/C=0, Transfer Command; D/C=1, Transfer Data.

8.4 3-Wire 9-Bit serial interface Timing

Parameter	Symbol	Conditions	Rating			Unit
			MIN	TYP	MAX	
Serial Clock Cycle (Write)	tscyww	SCL	100	–		ns
SCL “H” pluse width (Write)	tshw	SCL	40	–		ns
SCL “L” pluse width (Write)	tslw	SCL	40	–		ns
Data setup time (Write)	tsds	SDI	30	–		ns
Data hold time (Write)	tsdh	SDI	30	–		ns
Serial Clock Cycle (Read)	tscywr	SCL	150	–		ns
SCL “H” pluse width (Read)	tshr	SCL	60	–		ns
SCL “L” pluse width (Read)	tslr	SCL	60	–		ns
Access time	tacc	SDO (Read)	10			ns
Output disable time	toh	SDO (Read)	10		50	ns
CS “H” pluse width	tchw	CS	40	–		ns
CS-SCL time	tcss	CS (Write)	60	–		ns
	tcsrh	CS (Write)	65	–		ns

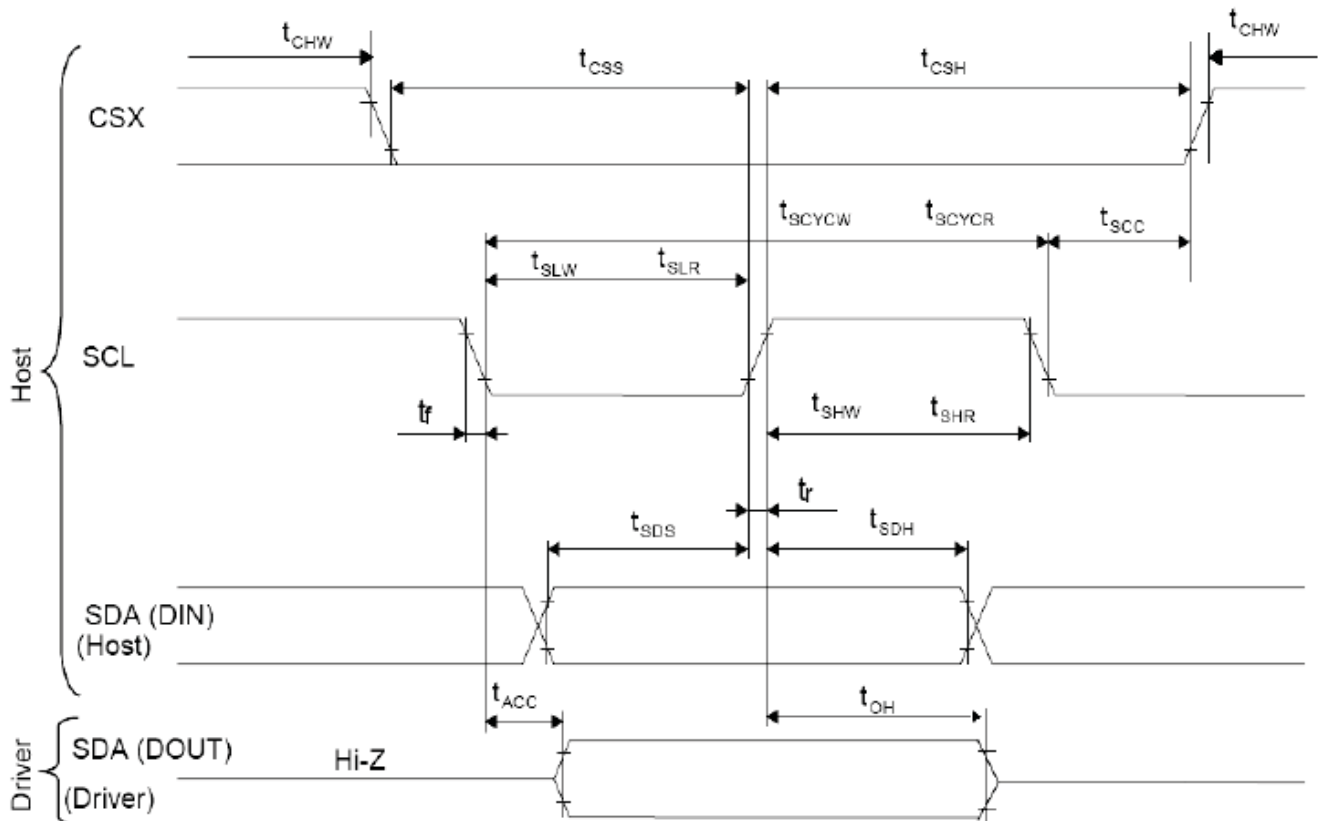

AC Characteristics of 3-Wire 9-Bit Serial Interface timing

8.5 Reset Timing

Parameter	Symbol	Rating			Unit
		MIN	TYP	MAX	
RESET	t_{RW}	10	-	-	μs
		-	-	5	ms
		-	-	120	ms

Note1: When Reset applied during Sleep In Mode.

Note2: When Reset applied during Sleep Out Mode.

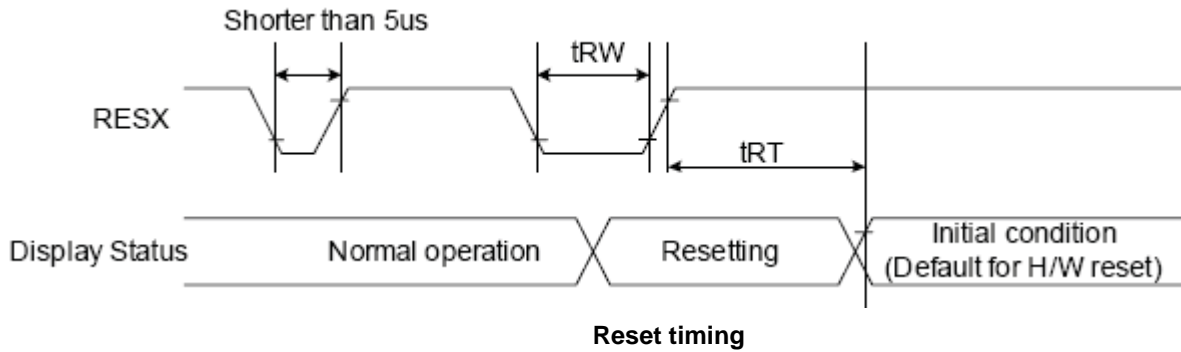

8.6 Power ON/Off Sequence

Parameter	Symbol	Rating			Unit
		MIN	TYP	MAX	
VSHD to RESET2 ending/ RESET2 starting to VSHD	t1	10			ms
RESET2 ending to SPI starting/ SPI ending to RESET2 starting	t2	10	-	50	ms
SPI starting to RGB starting/ RGB ending to SPI ending	t3	20	-	50	ms
RGB starting to BLU starting/ BLU ending to RGB ending	t4	50	-	-	ms
RGB ending to RESET1 starting	t5	20	-	-	ms

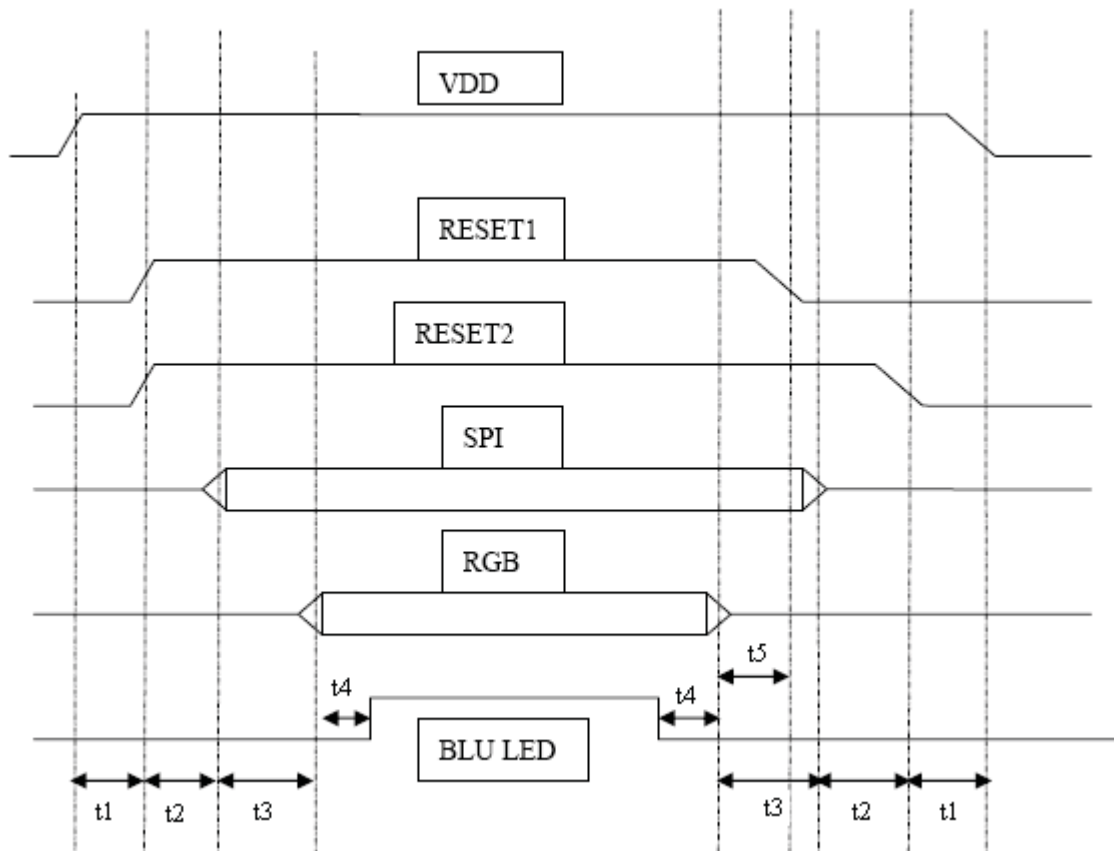

Note1: RESET1 Power down in sleep out mode.
 Note2: RESET2 Power down in sleep in mode.

9. Optical Specification

Backlight is ON

Ta=25°C

Item	Symbol	Condition	Min	Typ.	Max.	Unit	Remark
Contrast Ratio	CR	$\theta=0^\circ$	100	150	-		Note1 Note3
Response Time	Ton/ Toff	25°C	-	35	-	ms	Note1 Note4
View Angles	θT	$CR \geq 10$		55	-	Degree	Note 2
	θB			40	-		
	θL			40	-		
	θR			45	-		
Chromaticity	White	x	Brightness is on	0.301			Note5,
		y		0.321			
Luminance	L		80	100	-	cd/m ²	Note6

10.

Backlight is OFF

Ta=25°C

Item	Symbol	Condition	Min	Typ.	Max.	Unit	Remark
Contrast Ratio	CR	$\theta=0^\circ$		6.5	-		Note7
View Angles	θT	$CR \geq 2$		60	-	Degree	
	θB			60	-		
	θL			55	-		
	θR			60	-		
Chromaticity	White	x	Brightness is off	0.31			
		y		0.32			
Reflectance				7.0	-	%	

Note 1: Definition of optical measurement system.

Temperature = 25°C(±3°C)

LED back-light: ON, Environment brightness < 150 lx

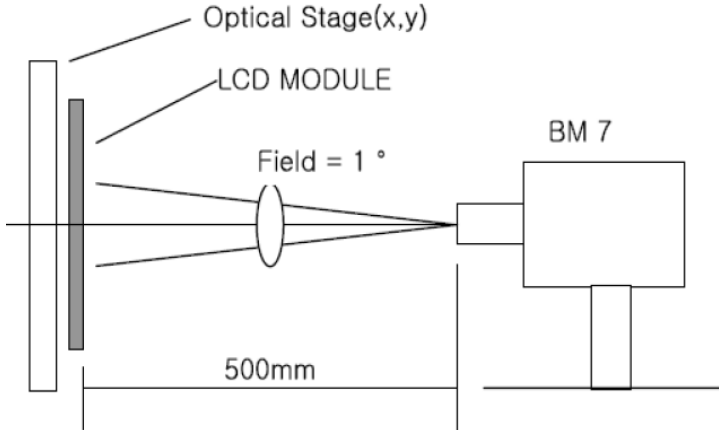

Note 2: Contrast ratio is defined as follow:

$$\text{Contrast Ratio} = \frac{\text{Surface Luminance with all white pixels}}{\text{Surface Luminance with all black pixels}}$$

Note 3: Response time is defined as follow:

Response time is the time required for the display to transition from black to white (Rise Time, Tr) and from white to black(Decay Time, Tf).

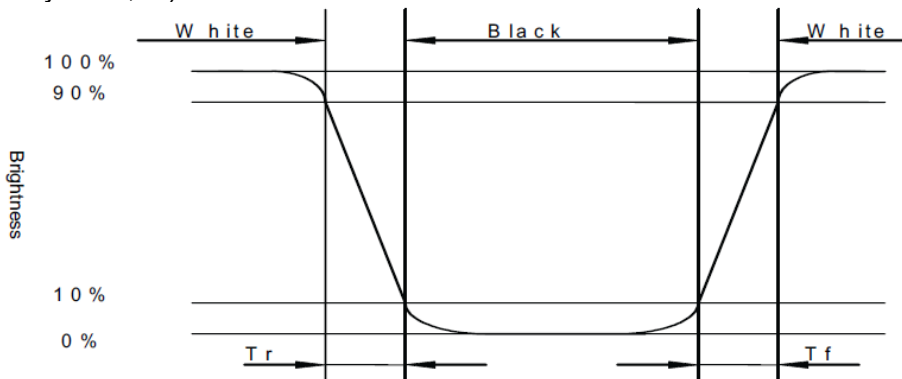

Note 4: Viewing angle range is defined as follow:

Viewing angle is measured at the center point of the LCD.

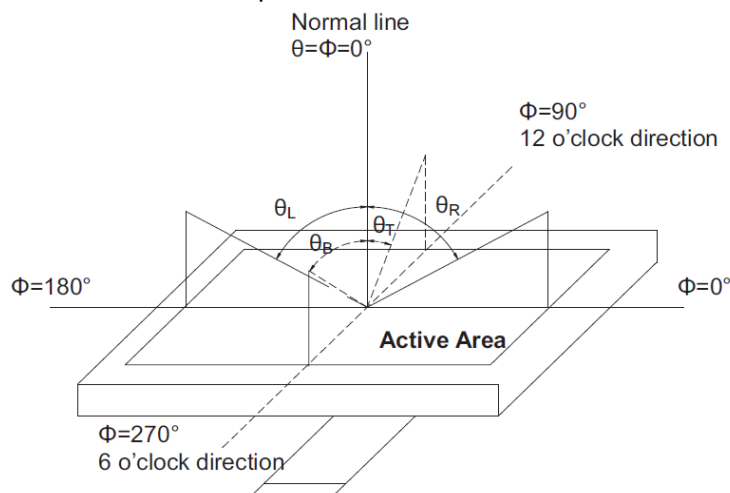

Note 5: Color chromaticity is defined as follow: (CIE1931)

Color coordinates measured at center point of LCD.

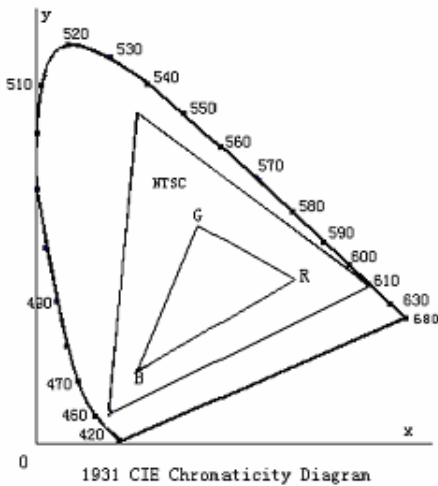

$$S = \frac{\text{area of RGB triangle}}{\text{area of NTSC triangle}} \times 100\%$$

Note 6: Luminance is defined as follow:

Luminance is defined as the brightness of all pixels “White” at the center of display area on optimum contrast.

Note 7: Reflectance measurement system is defined as follow:

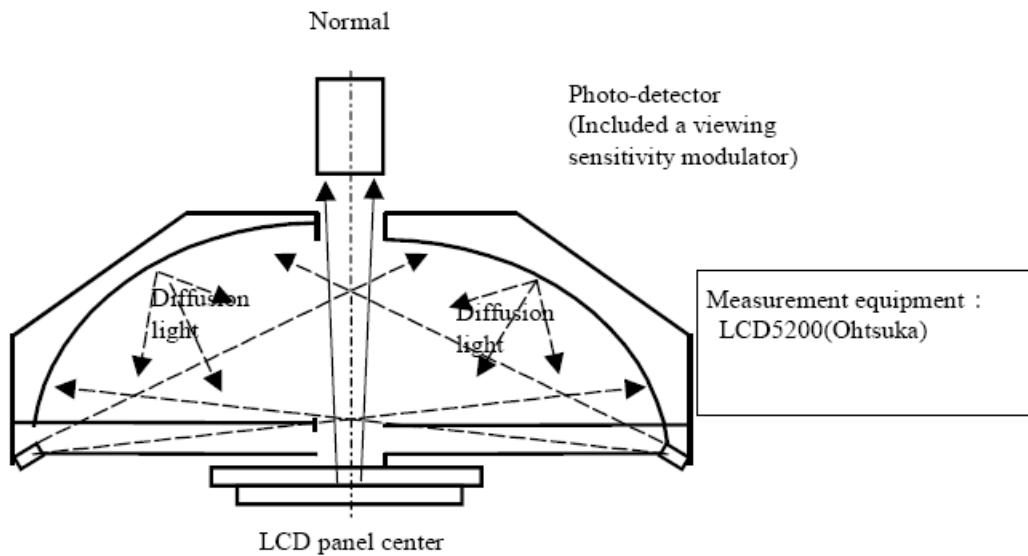

11. Environmental / Reliability Tests

No	Test Item	Condition	Judgment criteria
1	High Temp Operation	Ts=+60°C, 120hrs	Per table in below
2	Low Temp Operation	Ta=-20°C, 120hrs	Per table in below
3	High Temp Storage	Ta=+70°C, 120hrs	Per table in below
4	Low Temp Storage	Ta=-30°C, 120hrs	Per table in below
5	High Temp & High Humidity Storage	Ta=+40°C, 90% RH 120 hours	Per table in below (polarizer discoloration is excluded)
6	Thermal Shock (Non-operation)	-30°C 30 min~+70°C 30 min, Change time:5min, 10 Cycles	Per table in below
7	ESD (Operation)	C=150pF, R=330Ω · 5points/panel Air:±8KV, 5times; Contact:±4KV, 5 times;	Per table in below
8	Vibration (Non-operation)	Frequency range:10~55Hz, Stroke:1.5mm Sweep:10Hz~55Hz~10Hz 2 hours for each direction of X.Y.Z.	Per table in below
9	Shock (Non-operation)	60G 6ms, ±X,±Y,±Z 3times, for each direction	Per table in below
10	Package Drop Test	Height:80 cm, 1 corner, 3 edges, 6 surfaces	Per table in below

INSPECTION	CRITERION(after test)
Appearance	No Crack on the FPC, on the LCD Panel
Alignment of LCD Panel	No Bubbles in the LCD Panel No other Defects of Alignment in Active area
Electrical current	Within device specifications
Function / Display	No Broken Circuit, No Short Circuit or No Black line No Other Defects of Display

12. Precautions for Use of LCD Modules

11.1 Safety

The liquid crystal in the LCD is poisonous. Do not put it in your mouth. If the liquid crystal touches your skin or clothes, wash it off immediately using soap and water.

11.2 Handling

- A. The LCD and touch panel is made of plate glass. Do not subject the panel to mechanical shock or to excessive force on its surface.
- B. Do not handle the product by holding the flexible pattern portion in order to assure the reliability
- C. Transparency is an important factor for the touch panel. Please wear clear finger sacks, gloves and mask to protect the touch panel from finger print or stain and also hold the portion outside the view area when handling the touch panel.
- D. Provide a space so that the panel does not come into contact with other components.
- E. To protect the product from external force, put a covering lens (acrylic board or similar board) and keep an appropriate gap between them.
- F. Transparent electrodes may be disconnected if the panel is used under environmental conditions where dew condensation occurs.
- G. Property of semiconductor devices may be affected when they are exposed to light, possibly resulting in IC malfunctions.
- H. To prevent such IC malfunctions, your design and mounting layout shall be done in the way that the IC is not exposed to light in actual use.

11.3 Static Electricity

- A. Ground soldering iron tips, tools and testers when they are in operation.
- B. Ground your body when handling the products.
- C. Power on the LCD module before applying the voltage to the input terminals.
- D. Do not apply voltage which exceeds the absolute maximum rating.
- E. Store the products in an anti-electrostatic bag or container.

11.4 Storage

- A. Store the products in a dark place at $+25^{\circ}\text{C} \pm 10^{\circ}\text{C}$ with low humidity (40% RH to 60% RH). Don't expose to sunlight or fluorescent light.
- B. Storage in a clean environment, free from dust, active gas, and solvent.

11.5 Cleaning

- A. Do not wipe the touch panel with dry cloth, as it may cause scratch.
- B. Wipe off the stain on the product by using soft cloth moistened with ethanol. Do not allow ethanol to get in between the upper film and the bottom glass. It may cause peeling issue or defective operation. Do not use any organic solvent or detergent other than ethanol.

11.6 Cautions for installing and assembling

Bezel edge must be positioned in the area between the Active area and View area. The bezel may press the touch screen and cause activation if the edge touches the active area. A gap of approximately 0.5mm is needed between the bezel and the top electrode. It may cause unexpected activation if the gap is too narrow. There is a tolerance of 0.2 to 0.3mm for the outside dimensions of the touch panel and tail. A gap must be made to absorb the tolerance in the case and connector.

